

AVL WEAVING ACCESSORIES

SELVAGE ROLLERS

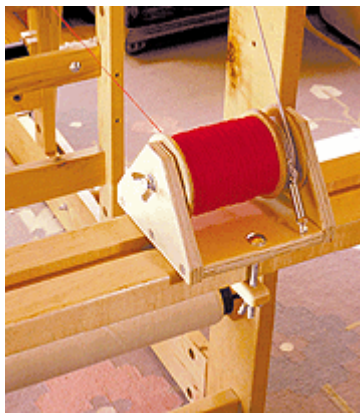

Illustrated Instructions

The AVL Selvage Roller has been designed to work in conjunction with the AVL Tension Box Track. Their purpose is to give you the ability to provide a different and separate tension on the selvage ends of your warp. This can be helpful as a means to lessen draw-in on certain types of warps. These rollers also come in handy if a warp end, or two, needs to be added to a warp that has already been wound. In this case, the tension setting on the rollers can be adjusted to match the warp tension.

Mounting the Selvage Roller

- 1.) Locate the tension tie-ups (2). Loosen up the threaded side of the quick link and remove one side of the cable. Wrap the cable around the upper back of your loom. Place the end of the cable back in the quick link and tighten up the threaded side.
- 2.) The Selvage Rollers are easily mounted on the loom. First, make sure that the Tension Box Track is in place on the loom. Temporarily remove the wooden clamp bar at the bottom of each Selvage Roller assembly and set each assembly onto the Tension Box Track, making certain that the side with the small screw eye is facing **away** from the loom. Then replace the wooden bar, washers, and wing nuts. The rollers can be located anywhere along the length of the track. Once you get them where you want them, simply tighten the wing nuts to hold them in place.
- 3.) Next, you will need to hook up the Tension Tie-Up. This is the long gray cord that is hanging from each of the quick links on the cables that you previously installed onto the upper back. Take the free end of the cord (the end with the spring) and wrap it three times around the wooden drum portion of the Selvage Roller as shown in Figure 1.

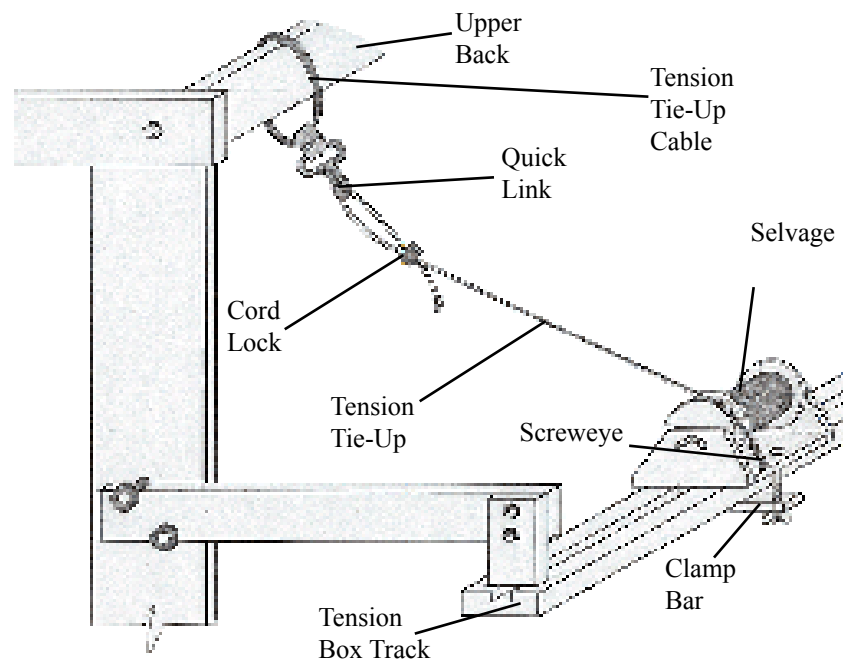
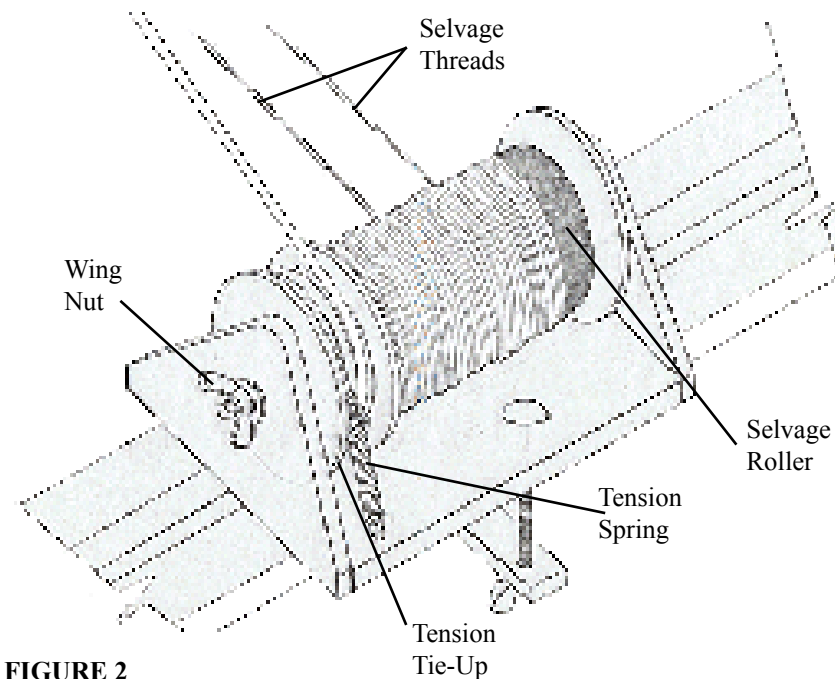

FIGURE 1

Next, attach the opened end of the spring to the small screw eye located near the back edge of the roller holder base. This tie-up can be adjusted by tightening or loosening the amount of tension on the cord. This is done by squeezing and sliding the black cord-lock up near the tension tie-up cable. The tighter you pull, the more tension you will get on the warp ends that come from the roller.

Winding the Rollers

The rollers can be removed from their holders by simply disconnecting the tension tie-up and unscrewing the wing nut on the side and removing the long bolt that serves as an axle for the rollers. The rollers can then be wound on your AVL Bobbin and Spool Winder or similar winding equipment. A single thread, or any manageable number of threads can be wound onto the black portion of the spool. If you use a yardage counter while winding, you will be able to accurately gauge how many yards you have wound onto each spool. Take care, before you start, that you will be winding the spools in the correct direction. When viewing the spool from the side with the tension drum, the threads will be wound in a **clockwise** direction and come off of the bottom of the spool as they head toward the loom (refer to Figure 2 to see what a correctly wound spool should look like).



When you replace the spools into their holders, make sure to place them so that the end with the wooden tension drum is on the same side of the holder as the small screw eye.

The tension tie-up can now be installed, as described in step #3. If a very light tension is required, you may modify the tie-up configuration by wrapping it around the tension drum only **two** times instead of three.

Routing the Threads

If the threads have been wound in the right direction and the rollers have been installed correctly, the warp threads should come off of the **bottom** of each roller as they head toward the loom. They should then be routed so that they go past the Separation Roller(s) on the loom and then go through their designated heddle(s), and then on through the reed and onto the Cloth Beam. Once these threads have been routed and secured to the Cloth Beam, the tension can be adjusted to give you the best weaving results.



AVL Looms, Inc.
3851 Morrow Lane, Suite #9
Chico, CA 95928-8305
530 893-4915
530 893-1372 fax #
info@avlusa.com
www.avlusa.com